

Performance Curves

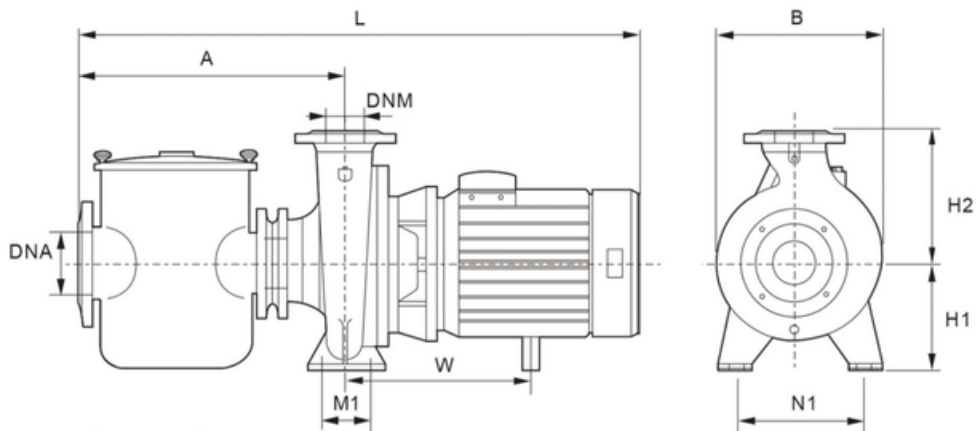
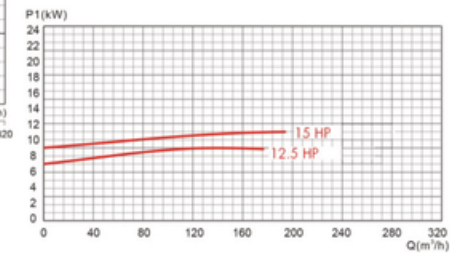
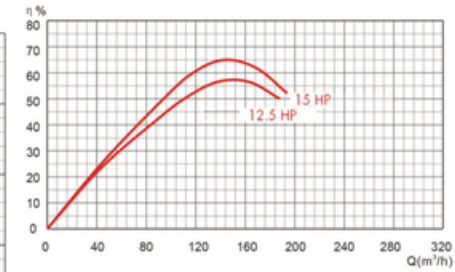
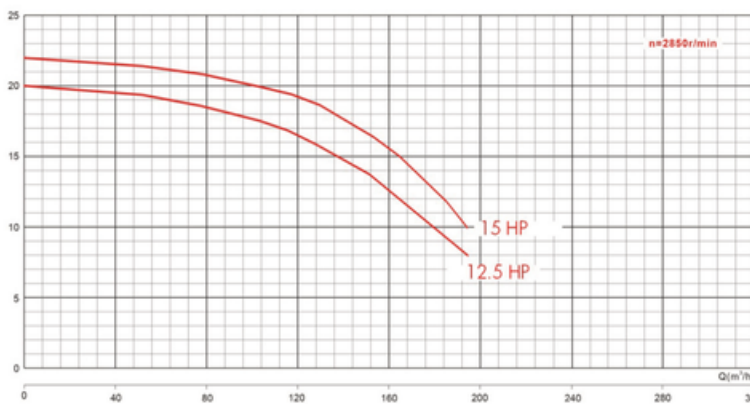
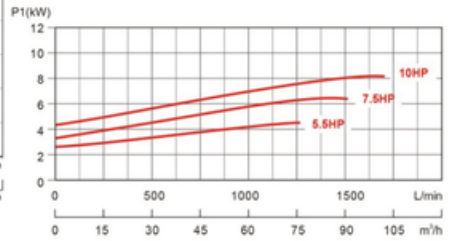
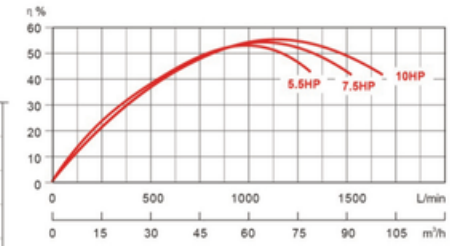
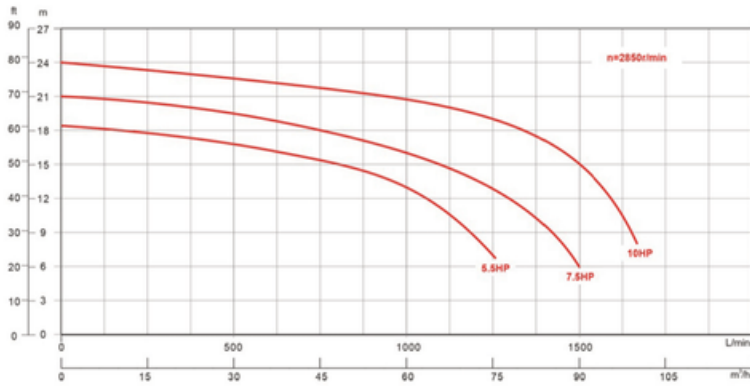

Dimensions (in mm)

Ref. Code	A	B	M1	W	L	N1	H1	H2	DNA	DNM
QRC550T	495	310	95	292	970	212	162.5	180	ø100	ø65
QRC750T	495	310	95	310	995	212	162.5	180	ø100	ø65
QRC1000T	495	310	95	310	995	212	162.5	180	ø100	ø65
QRC1250T	489	322	95	262	990	187	160	236	ø125	ø125
QRC1550T	489	322	95	275	1016	187	160	236	ø125	ø125